

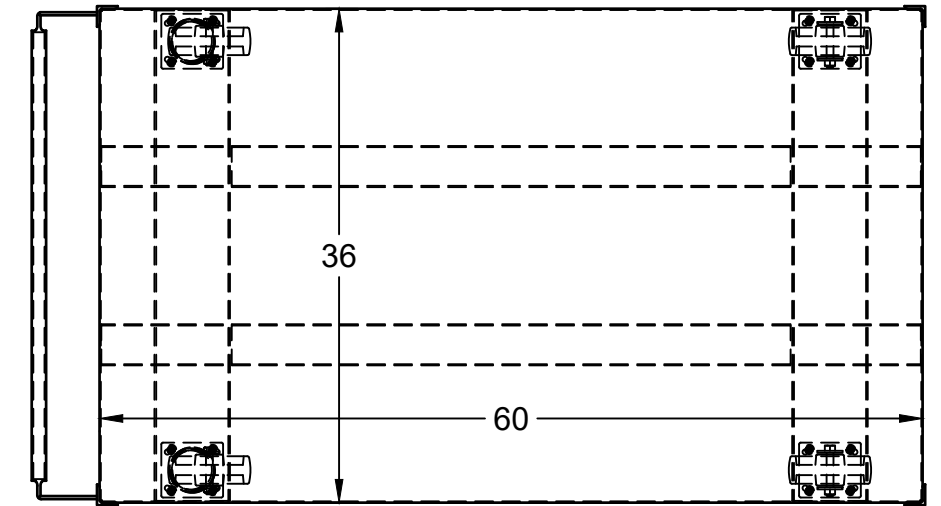

6x2 PH casters
2 swivel & 2 rigid

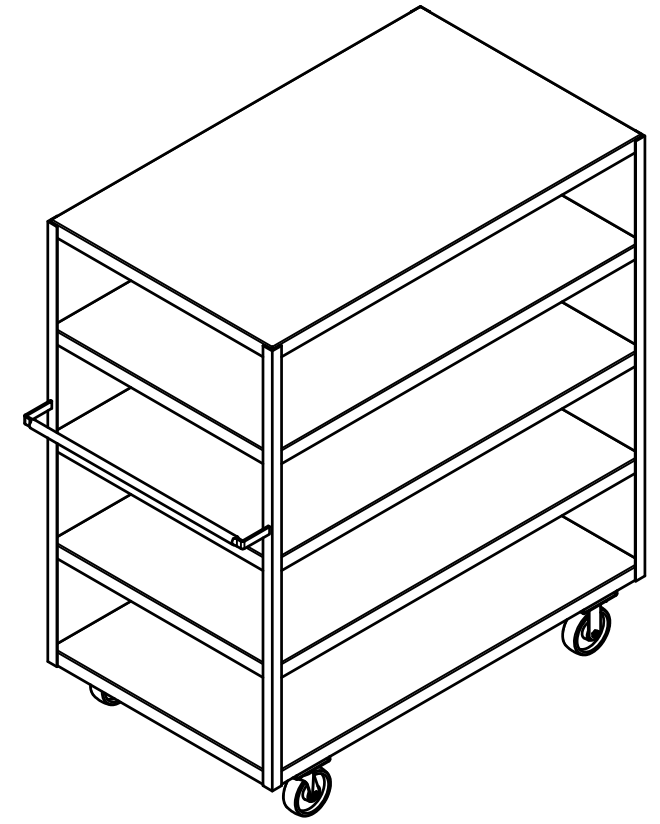
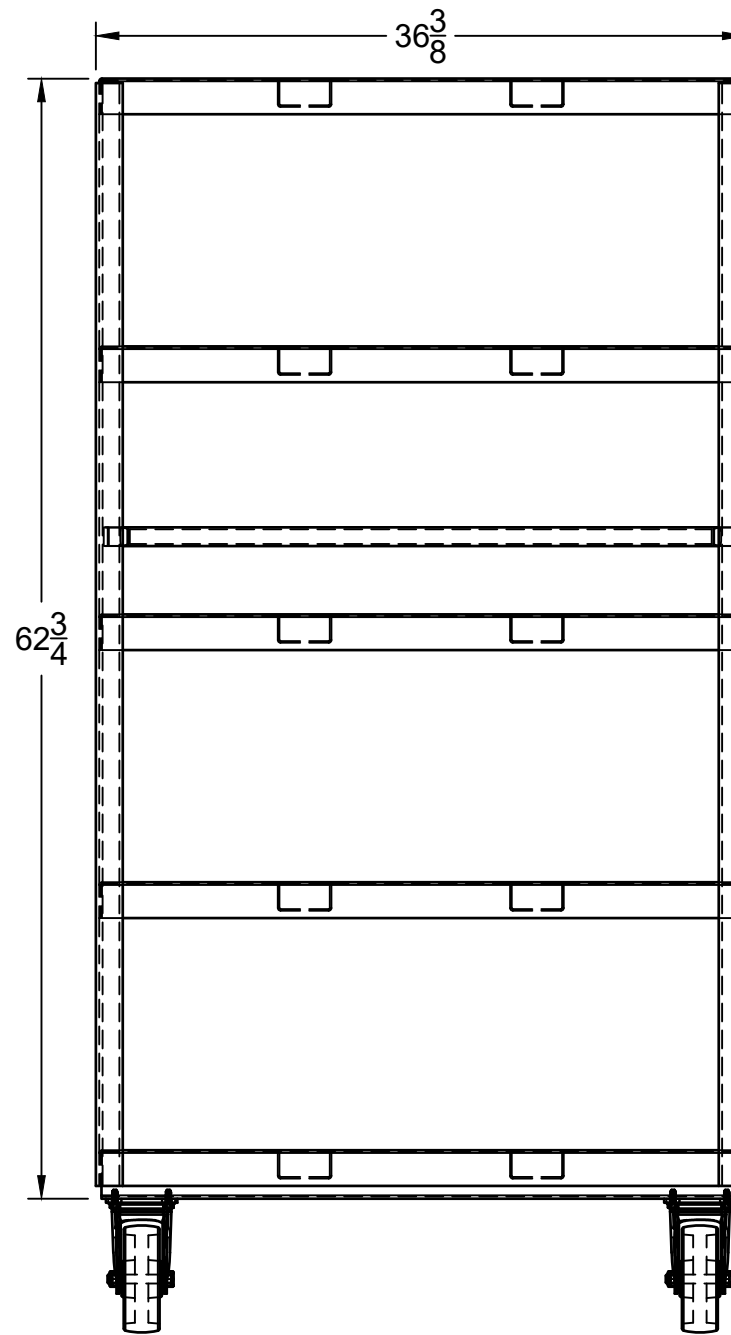

**FIRST PART
APPROVAL REQUIRED**

APPROVED BY _____
DATE _____

		PROJECT Shelf truck		
		TITLE Shelf truck - 2,000# capacity 60"L x 36"W x 70 1/4"H (5 shelves) w/6x2 phenolic casters		
APPROVED	SIZE	DUTY	DWG NO	REV
CHECKED	B	Heavy	13607C	
DRAWN	Jesse Pifer	2/5/2024	SCALE 1:10.75	WEIGHT 428 lbs
			SHEET 1/1	