

jasco[®]
~Since 1932~

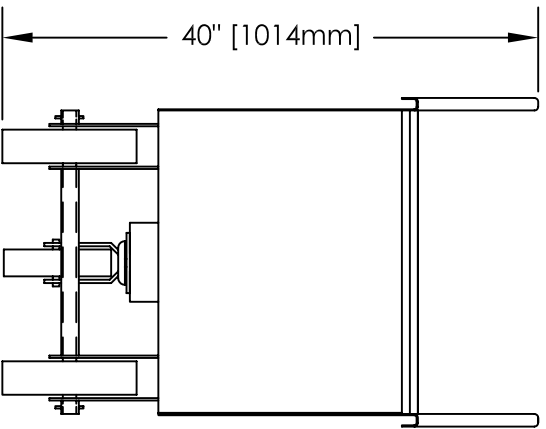

FRONT ELEVATION

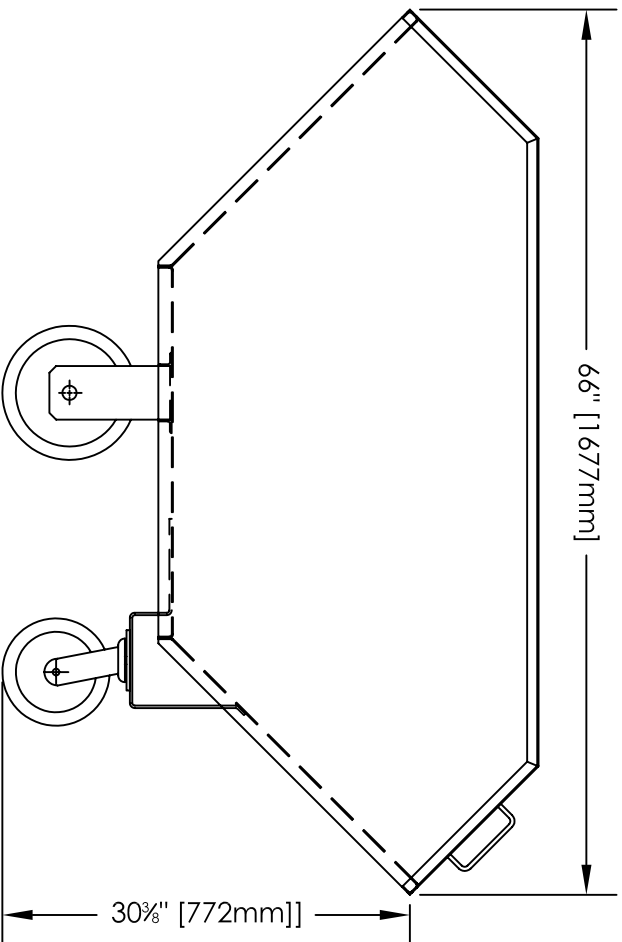

SIDE ELEVATION

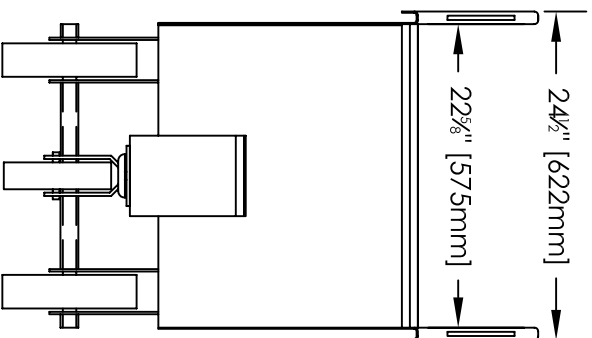

BACK ELEVATION

-NOTE- UNITS ARE TO BE WELDED WATER TIGHT.

**FIRST PART
APPROVAL REQUIRED**

APPROVED BY _____
DATE _____

DESCRIPTION		CHIP & WASTE TRUCK ~17.5 CUBIC FEET~	
DRAWN BY	GAS	SCALE	MATERIAL
CHKD	DATE	04/11/94	DRAWING NO.
TRACED	APPD		290200