

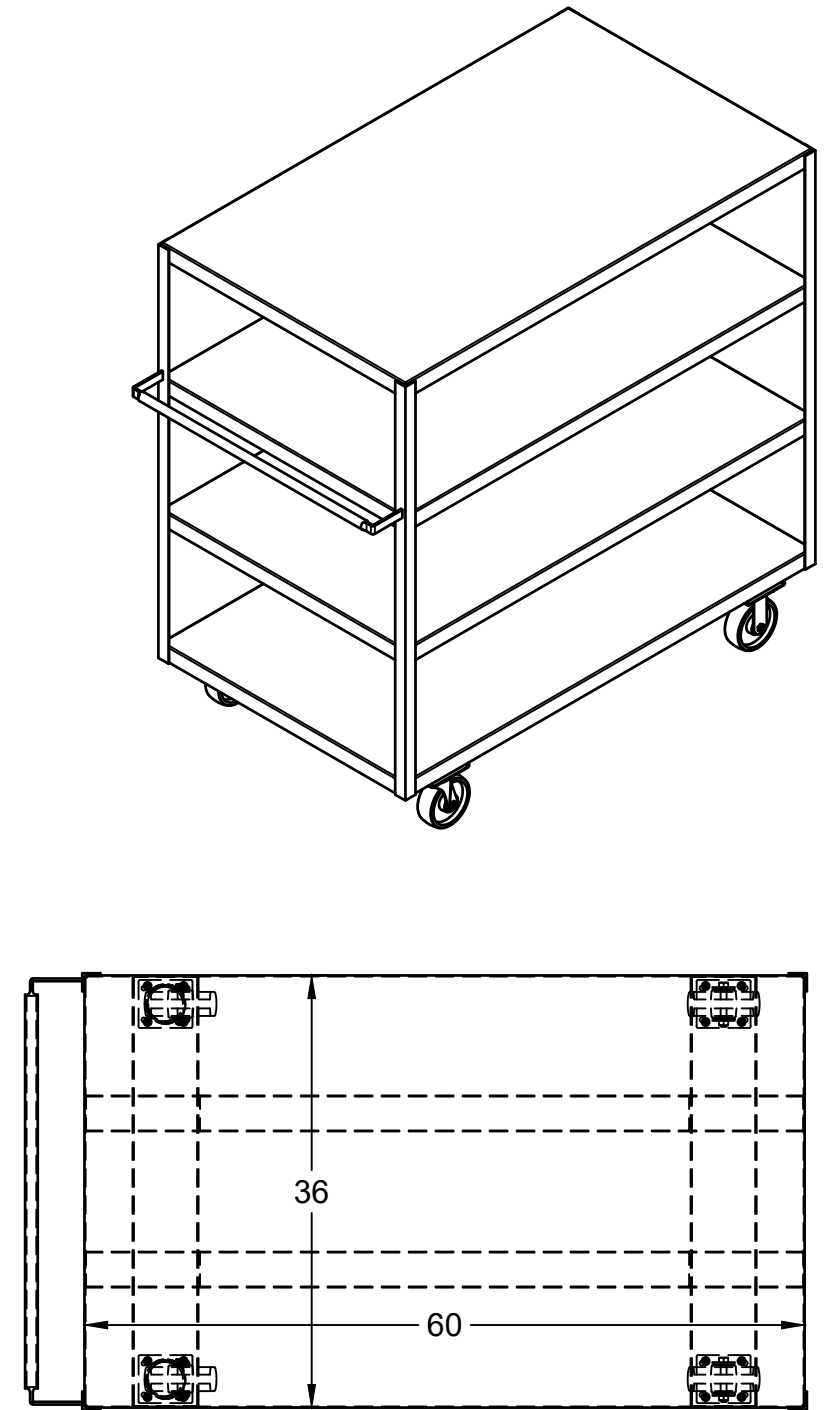

6x2 PH casters  
2 swivel & 2 rigid

**FIRST PART  
APPROVAL REQUIRED**

APPROVED BY \_\_\_\_\_  
DATE \_\_\_\_\_

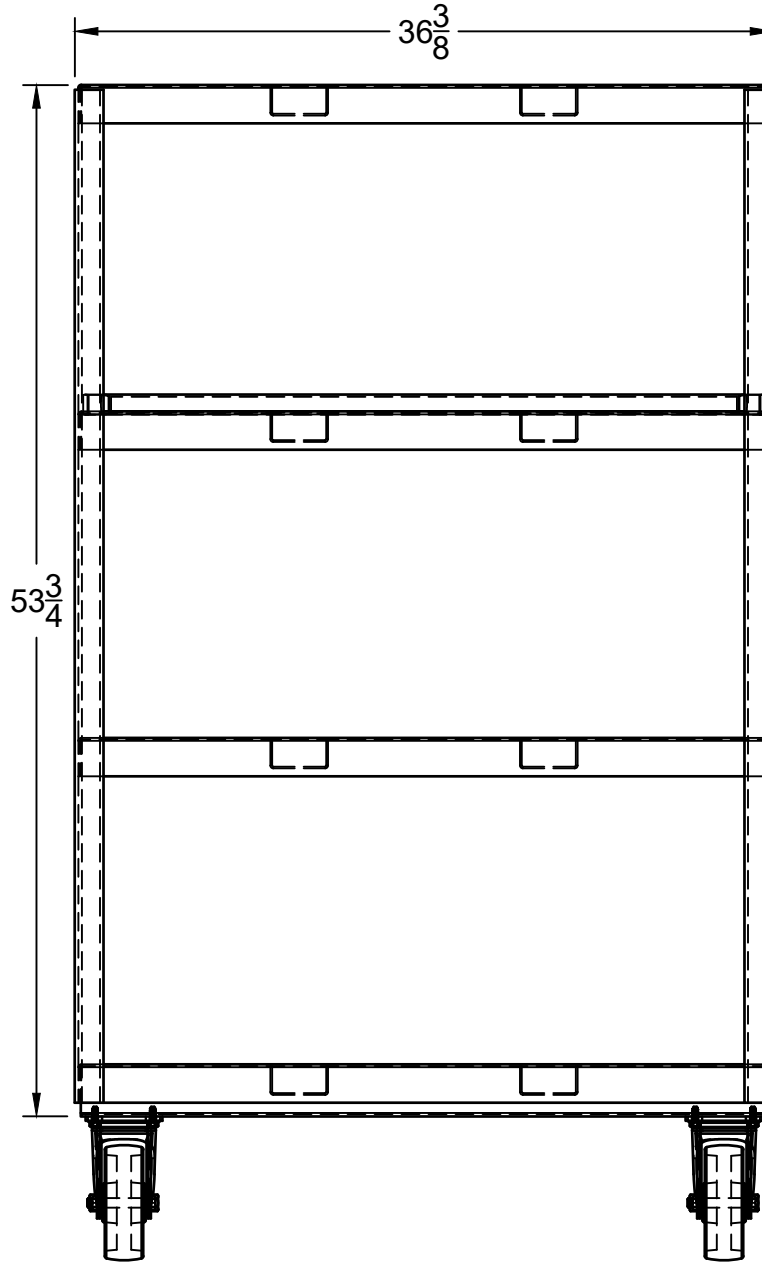

		PROJECT Shelf truck		
		TITLE Shelf truck - 2,000# capacity 60"L x 36"W x 61 1/4"H (4 shelves) w/6x2 phenolic casters		
APPROVED	SIZE	DUTY	DWG NO	REV
CHECKED	B	Heavy	13507C	
DRAWN	Jesse Pifer	2/2/2024	SCALE 1:10	WEIGHT 356 lbs
			SHEET 1/1	